

Dedicated to People Flow™

KONE

SUPERIOR TECHNOLOGY AND ABSOLUTE RELIABILITY FOR RETAIL NEEDS

KONE EcoMaster™ 130/135 Escalators and Inclined Autowalks

Bringing the customers to you



Quality, reliability and return on investment

Retail centers **need reliable solutions** to ensure continuous return on investment. Solutions based on superior technology and decades of expertise.

Another requirement is optimal lifecycle costs. Building owners need escalators that are cost-effective as well as **quick to maintain** – preferably before they break down!

Part of the shopping experience

Escalators and inclined autowalks smoothly connect different areas into one **uninterrupted shopping experience**, providing **easy access** everywhere from car parks to shop floors.

Made for retail needs

Convenience and efficiency translate to solutions that are **inviting and functional** to the end user and add value to the property.

Furthermore, escalators and inclined autowalks offer **attractive designs and colors** that create a pleasant atmosphere.

KONE – Your total solution partner

As one of the leading companies in the elevator and escalator business, KONE offers its customers:

- Elevators with exceptional power and performance – some without machine-rooms – that can be seamlessly integrated into buildings
- Reliable and elegant escalators to match customers' needs, from retail to transit applications, and with high levels of cost-effectiveness and performance
- Modernization and full replacement solutions to upgrade and maximize the potential of the product
- Comprehensive maintenance solutions for the entire lifecycle of the product
- Spare parts available globally within 24 hours.

With thousands of installations in over one hundred countries KONE has accumulated know-how and expertise second to none. The reliability and quality KONE offers can be seen in many locations around the world.



KAMPPI SHOPPING CENTRE, FINLAND

DINING, SHOPPING AND SPORTS IN A MODERN COMPLEX AT THE HEART OF HELSINKI. 65 ELEVATORS AND ESCALATORS CONNECT THE SIX LEVELS OF THIS COMPLEX TO EACH OTHER AND INTO THE MAIN BUS STATION OF THE CITY UNDERNEATH IT.



KAUFHAUS SEVENS, GERMANY

LUXURY SHOPPING CENTRE ON THE HISTORIC KÖNIGS ALLEE OF DÜSSELDORF.

Superior retail solution

Elegance and ambience

- Numerous lighting options that guide the customers and **enhance atmosphere**
- Great window-shopping opportunity
- The stylish solid or ambient glass balustrades according to customer need and taste



Skirt spot lights



Comb lighting



Handrail lighting



Glass cladding



Traffic lights on decking



Trolley protection in autowalks

Tailored for retail environment

- Elegant and **timeless design** to welcome the customers
- Visual options such as 7 handrail colour options for **flexible integration** into the building
- **Efficient and smooth ride** to maximize the shopping experience
- Clear indicator and directional signalisation for easy guidance
- **Compact installation** size and accurate fit with balustrade extensions

Ecological design

- **Energy efficient and user-friendly** stand-by speed to enhance energy effectiveness
- **Absolute ecological and fire safety** with lubrication free chain
- Low oil consumption

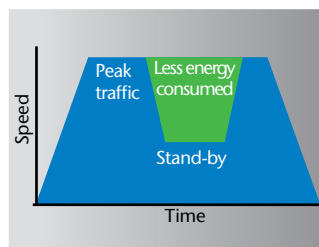

Stand-by speed



Oil use comparison



Lubrication free chain



Outdoor options



Primed sheet steel cladding



Stainless steel cladding



Stainless steel front plate

Absolute and uncompromising reliability

- For durability and smooth aesthetics stainless steel available for cladding, skirts and front plate
- Operation even in compromising conditions through optional semi-outdoor weatherproofing
- Based on KONE technology that will last

Technological superiority

- Unsurpassed energy efficiency with a chainless drive design and KONE's technically superior planetary gear
- Advanced components to give a lifetime of reliable performance
- KONE expertise and know how in maintenance and service



KONE EcoMaster™ Drive



Diagnostic display

Safety and effectiveness

- Maximum availability through advanced control system
- Fast and effective troubleshooting through built-in diagnostics
- Extensive safety and monitoring options

KONE EcoMaster™ 130

KONE EcoMaster™ 130 basic data	
Inclination	30° or 35°
Maximum rise	15 meters with 30°, 6 meters with 35°
Operational environment	Indoor, semi-outdoor, outdoor
Step width	600 mm, 800 mm or 1000 mm
Balustrade type	Glass/ sandwich panels/ stainless steel inclined solid
Balustrade height	1000 mm, 1100 mm
Speed	0.5 m/s, 0.65 m/s, 0.2 m stand-by speed optional
Code	EN and ANSI

KONE EcoMaster™ 130 width dimensions			
Step width (A)	600 mm	800 mm	1000 mm
Width between handrails (B)	787 mm	985mm	1183 mm
Escalator width (C) **	1100 mm	1300 mm	1500 mm
Pit width (D) **	1160 mm	1360 mm	1560 mm

**): With special outer cladding add 20 mm per side.

Head dimensions								
Type	Step width	AA	BB	CC	DD	EE	FF	HH
35-1.0-2	1000/800/600	2136	2439	1.4281H	1753	1170	3850	1075
30-1.0-2	1000/800/600	2194	2469	1.7321H	1800	1140	4150	1045
30-1.5-2	1000/800/600	2194	2602	1.7321H	1800	1140	4150	1045
30-1.5-3	1000/800/600	2594	3002	1.7321H	1800	1140	4150	1045

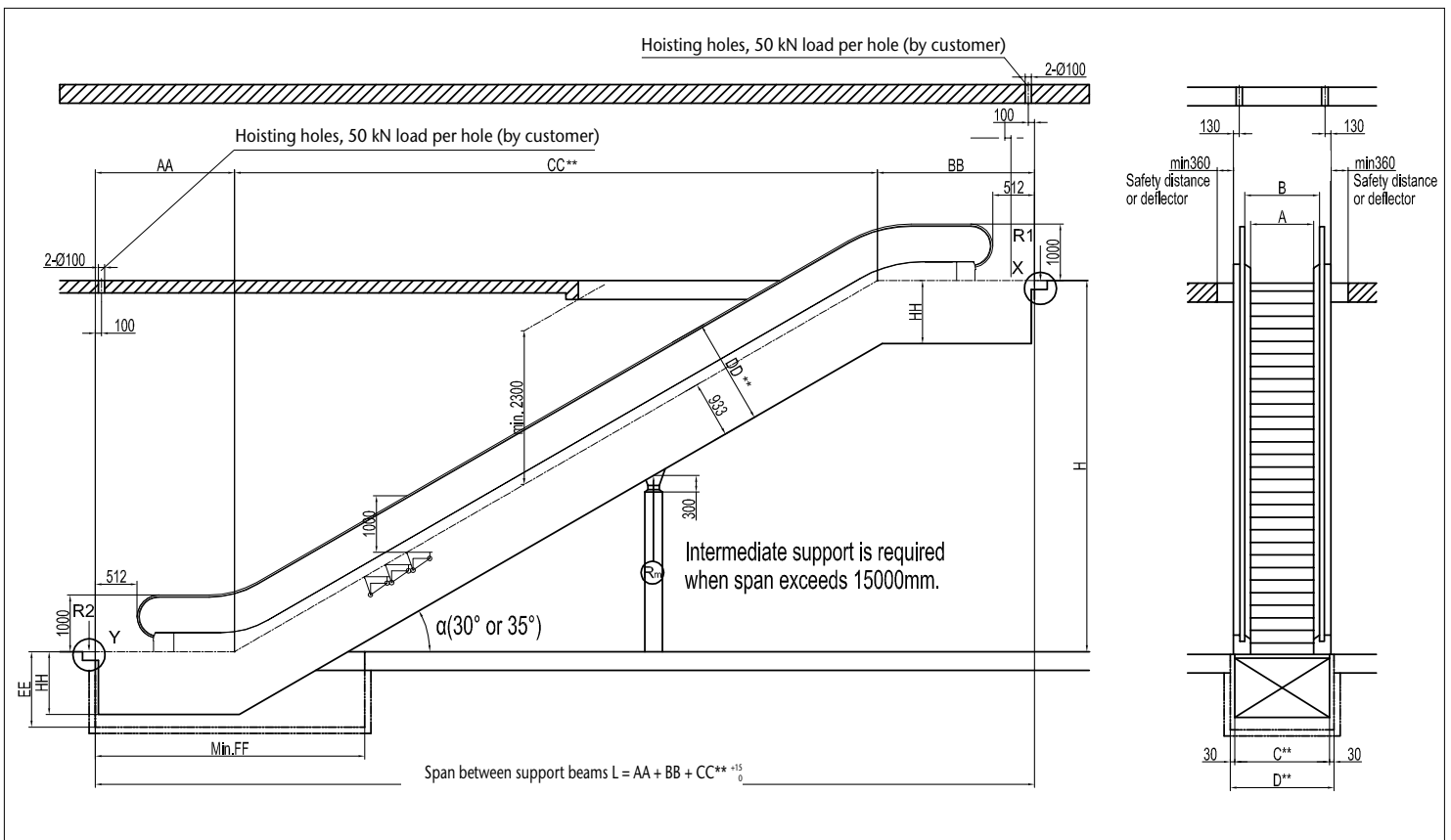



KONE provides innovative and eco-efficient solutions for elevators, escalators and automatic building doors. We support our customers every step of the way; from design, manufacturing and installation to maintenance and modernization. KONE is a global leader in helping our customers manage the smooth flow of people and goods throughout their buildings.

Our commitment to customers is present in all KONE solutions. This makes us a reliable partner throughout the life-cycle of the building. We challenge the conventional wisdom of the industry. We are fast, flexible, and we have a well-deserved reputation as a technology leader, with such innovations as KONE MonoSpace® KONE MaxiSpace™, and KONE InnoTrack™. You can experience these innovations in architectural landmarks such as the Trump Tower in Chicago, the 30 St Mary Axe building in London, the Schiphol Airport in Amsterdam and the Beijing National Grand Theatre in China.

KONE employs over 32,500 dedicated experts to serve you in over 50 countries.

KONE Corporation
www.kone.com

THIEN NAM Elevator J.S Corporation **(The official appointed distributor for KONE products in Vietnam)**

HEAD OFFICE

1/8C Hoang Viet Street Ward 4, Tan Binh Dist - Ho Chi Minh City

Tel: (84-8) 54490210 ~ 15

Fax: (84-8) 54490208 ~ 9

Web: www.tne.vn

Email: info@tne.vn

HA NOI BRANCH OFFICE

119 Nguyen Ngoc Nai Street, Thanh Xuan Dist - Ha Noi Capital

Tel: (84-04) 35665759 ~ 61

Fax: (84-04) 35665763 ~ 65

Email: cn-hanoi@tne.vn

DA NANG BRANCH OFFICE

38 Le Hong Phong Street, Hai Chau Dist - Da Nang City

Tel: (84-0511) 3829015

Fax: (84-0511) 3897969

Email: cn-danang@tne.vn

NHA TRANG BRANCH OFFICE

92C Le Hong Phong Street, Phuoc Hai Ward - Nha Trang City

Tel: (84-058) 3870111

Fax: (84-058) 3870112

Email: cn-nhatrang@tne.vn

CAN THO BRANCH OFFICE

97B1 Cai Khe Trade Center, Can Tho City

Tel: (84-0710) 3762403

Fax: (84-0710) 3762430

Email: cn-cantho@tne.vn